



Electric Wok User Manual



Model No.: TSK-2241G
Item No. 900398
Rev 1

READ AND SAVE THESE INSTRUCTIONS

Note: The specifications, markings and/or components of this appliance are subject to change without prior notice.

1	Important Safety Instructions	3
2	Components.....	6
3	Operating Instruction.....	7
3.1	Preparation.....	7
3.2	Using Your Appliance	8
3.3	Stir-Frying.....	9
3.4	Shallow Frying.....	9
3.5	Deep Frying.....	9
3.6	Braising & Stewing	10
4	Care Of Your Product	10
5	Wiring Diagram	11
6	Service	12
7	Guarantee	13

1 Important Safety Instructions

WARNING Before using your appliance, please read all instructions.

- Check if the rated voltage of the appliance is compatible with the local power system. Confirm if all the attachments are included in the package, otherwise contact the responsible vendor.
- Children should be supervised to ensure that they do not play with the appliance
- This appliance is not intended for use by persons (including children) with reduced physical, sensory or mental capabilities, or lack of experience and knowledge, unless they have been given supervision or instruction concerning use of the appliance by a person responsible for their safety.
- Use this appliance only for its intended uses as described in manual. Do not use corrosive chemicals or vapours with this appliance
- Unplug from electrical outlet when not in use, or cleaning. To unplug, grasp the plug and pull from power outlet. Never pull cord.
- The temperature control probe must be removed before the appliance is cleaned and the appliance power inlet must be dried before the appliance is used again.
- Do not immerse the probe in water or liquid.
- Only the temperature control probe supplied is to be used with this appliance.
- Attach temperature control probe to Wok BEFORE connecting to power outlet
- To avoid risk of electrical shock when in use, do not put the appliance in water or any other liquid.
- Never carry the appliance by the cord.
- The use of attachments not recommended or sold by the manufacturer may cause electric shock or injury.

- Do not operate the appliance with a damaged cord or plug. If the supply cord is damaged, it must be replaced by the manufacturer, its service agent or similarly qualified persons in order to avoid a hazard.
- Do not operate any appliance if the appliance malfunctions, is dropped or damaged in any manner. Return appliance to the nearest authorised service agent or similarly qualified person for a thorough examination, repair, electrical or mechanical adjustment.
- Do not reach for an appliance that has fallen into water. Switch 'OFF' at the power point and unplug immediately.
- Do not use this appliance outdoors.
- Do not let the cord hang over the edge of a table or counter, or touch hot surfaces.
- Do not operate or place any part of this appliance on or near any hot surfaces, such as a gas or electric burner, or in a heated oven.
- Do not use an appliance for other than its intended use.
- Do not attempt to repair or disassemble the appliance. There are no user serviceable parts.
- This product has not been designed for any uses other than those specified in this booklet.
- Do not use this appliance with an extension lead.
- DO NOT MOVE this appliance when it is in operation.
- Ensure the packaging of this appliance is disposed of properly. Keep plastic bags away from babies and children.
- Avoid using on metal surfaces e.g. sink.
- This product should not be used in the immediate vicinity of water, such as a bathtub, washbowls, swimming pool etc. where the likelihood of immersion or splashing could occur.

- Ensure the power cord is kept away from the Wok sides when in use.
- Do not leave the appliance unattended when switched on.
- Take care when removing food from the Wok.
- Do not operate the appliance when empty.
- Do not cover when deep frying.
- Use only suitable utensils for non-stick surfaces to avoid scratching.
- When using the Wok, ensure that there is sufficient air space above and all sides for air circulation.
- This product is intended for normal domestic/household use only.
- This appliance is not intended to be operated by means of an external timer or separate remote-control system.
- The temperature of accessible surfaces may be high when the appliance is operating. Avoid touching hot surfaces, use handles and knobs.
- Use extreme caution when disposing of hot grease, oil or liquids.
- Do Not tip grease or oils down the sink.
- Allow to cool completely before cleaning.
- **WARNING:** Charcoal or similar combustible fuels must not be used with this appliance.
- No liability can be accepted for any damage caused by non-compliance with these instructions or any other improper use or mishandling of appliance.

READ AND SAVE THESE INSTRUCTIONS

2 Components

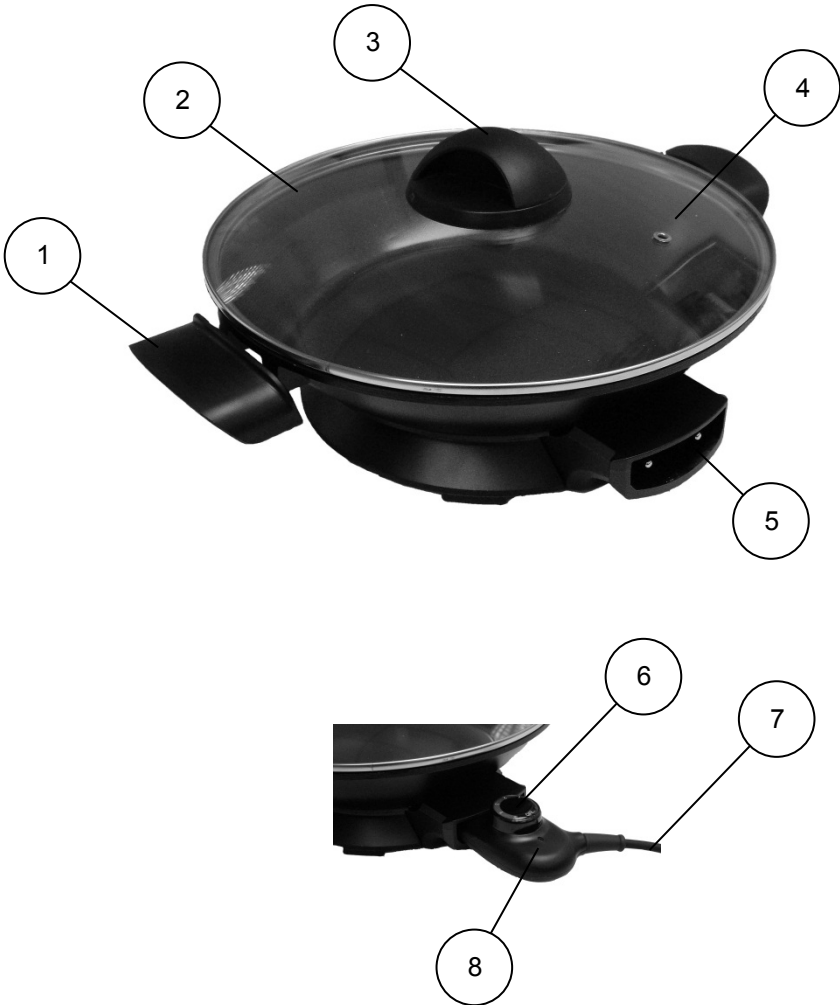

- 1 Carry Handle
- 2 Glass Lid
- 3 Lid Handle
- 4 Steam Vent

- 5 Controller Socket
- 6 Temperature Controller
- 7 Power Cord
- 8 Indicator Light

3 Operating Instruction

- Remove all packaging from the appliance before use and dispose of thoughtfully.

3.1 Preparation

Note: When using the Appliance for the first time, the unit may emit a smell. This is no cause for alarm and is caused by the initial heating of the element. It will soon dissipate.

- The non-stick surface allows you to cook without oils or fats. To achieve continued good results from your appliance, it is essential that you follow the care and cleaning directions in this Instruction Manual.
- Unplug the temperature controller from the appliance before cleaning. Never immerse the temperature controller, its cord or plug into water or any other liquid.
- Wash the appliance and lid in warm soapy water, rinse with clean water and dry.
- Ensure the connector pins where the controller plugs into are very dry.
- Place the Appliance on a flat level surface.
- Read the following section on “Using your Appliance” then ‘condition’ the non-stick surface inside the Appliance by brushing a thin layer of cooking oil onto the surface then allow the Appliance to heat up on setting 3 for 5-minutes. Then shut-off and allow to cool. Wipe off any excess oil on the surface.
- Conditioning should be done after every six weeks or sooner depending on use.
- Extremely high temperatures can cause discolouration and reduce the life of any non-stick surface. Generally, a medium setting on your Appliance will provide sufficient heat for most cooking needs.
- If high temperatures are necessary, introduce the heat gradually by preheating the Appliance on a medium setting for a few minutes.
- The use of ‘SOFT’ utensils (e.g. nylon, wood, plastic) will prolong the life of the non-stick coating. Metal utensils can damage the surface and should not be used.

Note: Even if the surface is scratched it will not greatly affect the non-stick performance of your Appliance. Never cut food in the Appliance.

- The non-stick material is non-toxic if inadvertently ingested.

3.2 Using Your Appliance

- Before first use, read the section “Preparation” and “Care of your Product”
- Plug the temperature controller into the Appliance ensuring it is pushed all the way in.
- Turn the dial down to the lowest setting “Min”
- Connect the mains plug in to a suitable power point and switch on.
- Turn the control dial to your desired setting. i.e. Min / 1 / 2 / 3 / 4 / 5. (5 being the hottest). Note: Depending if the heat setting is set high enough, the indicator lamp will illuminate indicating the element is heating.
- As soon as the selected temperature has been reached, the element will turn off indicated by the indicator light turning off.
- When the Appliance cools down, the thermostat controller will turn the element back on. At the same time the indicator lamp will illuminate indicating the Appliance is heating.

Note: The thermostat inside the controller will cycle on and off to maintain the selected heat setting and will be indicated by the light turning on and off.

- Always turn the temperature controller dial to the lowest setting “Min” when finished, then:
- Switch off and pull out the mains plug from the power point.
- Pull the temperature controller from the Appliances’ connecting socket.
- Allow the Appliance to completely cool before cleaning and storing.

CAUTION:

Use extreme caution when cooking with oil. Oil severely over-heated may ignite. If this occurs, do not add water. Immediately turn power off at the power point then cover the Wok with the lid and/or fire blanket to extinguish the flames.

Depending on what is being cooked, steam may vent from the Steam Vent Hole in the glass lid. To prevent personal injury, keep away from this hole when in use as steam is very hot.

3.3 Stir-Frying

- Vegetables and meat should be cut into uniform shapes and sizes before cooking.
- Slice meats into thin strips so that they can cook quickly.
- If stir-frying marinated meat, drain off excess marinades as it tends to boil and burn.
- Ensure that oil placed inside the Appliance is preheated correctly before cooking.
- The lid is not required to be used during stir-frying. Take care as hot liquids may be splashed.

3.4 Shallow Frying

- Shallow frying is a method used to cook and crisp food in a small amount of oil. The food is cooking at a lower temperature so that a brown crust forms on the underside. The food is then turned over to brown the other side. Usually 1-cup of oil is sufficient for shallow frying.
- The Tempura Rack is convenient for use to allow food to drip off any excess oil.

3.5 Deep Frying

- Deep fried food should be crispy on the outside and tender on the inside. The food should be coated with batter or breadcrumbs and placed in hot oil.
- Preheat the oil to the desired temperature before adding in the food. Do not cover the Appliance with lid when deep frying. This will prevent foaming or spattering of oil from condensation water droplets.

- Wipe moisture from foods to avoid any spattering of oil.
- Do not fill the Appliance with more than 5-cups of oil. For best results, use vegetable oil.
- Cook food pieces a few at a time. This prevents lowering the oil temperature and food from forming a soggy crust.
- Drain the food on the provided Tempera Rack or on a paper towel as soon as it is removed from the oil.
- Always allow the oil to completely cool before removing it from the Appliance.

3.6 Braising & Stewing

- The Appliance can be used to make your favourite stews. The lid should be left on when stewing. Braising is a variation to stir-frying where liquid is added at the end of stir-frying and the ingredients are left to simmer, usually uncovered.

4 Care Of Your Product

- After use and before cleaning, Turn temperature control to lowest setting, remove the plug from the power point and wait for the Appliance to cool.
- Remove the controller from the Appliance. The controller and probe may be warm after use, so be careful when removing it.
- If necessary, wipe control and cord with a damp cloth and thoroughly dry. Let Appliance cool before washing.

NEVER PUT COLD WATER INTO A HOT APPLIANCE as this may cause it to go out of shape and may damage the non-stick coating.

- Wash the non-stick coating (inside and out) in clean, warm water and mild detergent after EACH use. Failure to do this could result in a build-up of food residue, particularly above the element area on the cooking surface of the Appliance.
- Do not use steel wool or coarse scouring pads. To remove stubborn spots use a plastic mesh pad, or products with directions stating 'safe for cleaning non-stick surfaces'.

- Wash the lid in warm soapy water, rinse with clean water and dry. Do not use steel wool or coarse scouring pads on the lid.
- The Appliance can be washed in the Dishwasher. The lid must only be washed on the top rack. Remove the controller from the Appliance first. **DO NOT place the Controller in the dishwasher.**
- Do not use spray-on cleaners, harsh chemicals or solvents etc. as this will affect the performance of the Non-Stick surface on the cooking plates.
- Dry the components and then store away.
- Do Not place the controller and plug inside the Appliance as the non-stick surface may be scratched.

CAUTION:

The temperature controller, probe and receptacle in the Appliance must always be completely dry before use.

The temperature controller must be removed before the Appliance is cleaned.

5 Wiring Diagram

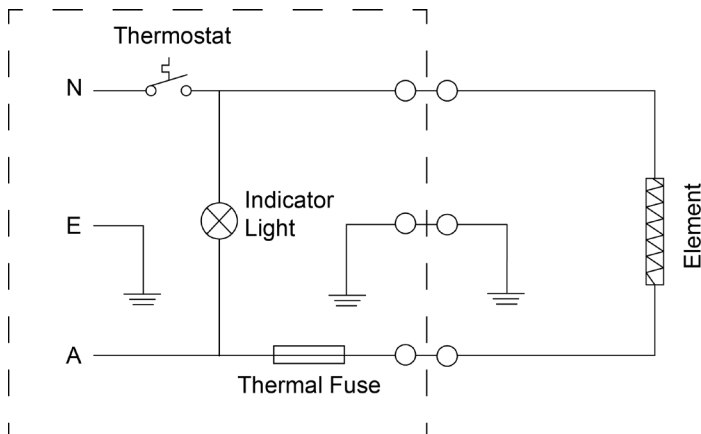

6 Service

CAUTION. To reduce the risk of electric shock, do not disassemble the Appliance. No user serviceable parts inside.

Do not operate the product with a damaged cord or plug, or after the product malfunctions, or appears damaged in any way.

Return the complete product to the place of purchase for inspection, repair or replacement.

In some products, the replacement by the user of the flexible cord is not intended.

Special tools may be required to disassemble the product or replace the cord.

Return the complete product to the place of purchase for inspection, repair or replacement.

7 Guarantee

WHAT'S COVERED?

- 1.1 H.E. Group Pty Ltd ("us" "we" or "our") warrants this good for a full replacement or refund for a period of twelve months from the date of purchase.
- 1.2 This warranty covers materials and workmanship defects only.

WHAT IS NOT COVERED?

- 2.1 This good is for household use only and if used in any way other than as detailed in the instruction manual will void this warranty.
- 2.2 This warranty does not apply to defects arising from abuse, alteration, unauthorised or unreasonable use of the good, nor does it cover general deterioration due to usage.
- 2.3 This warranty does not apply to accessories due to general deterioration or acts beyond human control.

WHAT WE WILL DO

- 3.1 We will replace the good or provide a refund to the value of the purchase price, if a defect is discovered in the good during the warranty period of twelve months subject to verification of defect or malfunction and the date and proof of purchase and purchase price.

WARRANTY COSTS

- 4.1 Once we have received the goods and you have complied with the warranty, our costs associated with the warranty claim will be borne by us.
- 4.2 No responsibility will be taken for goods lost, mislaid or damaged whilst in transit.

GENERAL

The benefits of this warranty are additional to any other rights and remedies you may have under law.

- 5.1 Our goods come with guarantees that cannot be excluded under Australian Consumer Law. You are entitled to a replacement or refund for a major failure and compensation for any other reasonably foreseeable loss or damage. You are also entitled to have the goods repaired or replaced if the goods fail to be of acceptable quality and the failure does not amount to a major failure.
- 5.2 Notwithstanding 5.1, except as provided for in this warranty, all express and implied warranties and conditions under statute or general law as to the merchantability, description, quality, suitability or fitness of the goods for any purpose, or as to design, assembly, installation, materials or workmanship or otherwise are (where permitted under law) expressly excluded.
- 5.3 To the extent permitted by law, our total liability for loss or damage of every kind related to the good in any way whatsoever is limited to the amount paid to the retailer by you for the good or the value of the good.
- 5.4 These terms and conditions supersede and exclude all prior and other discussions, representations (contractual or otherwise) and arrangements relating to the supply of the goods or any part of the goods. This includes representations not made by us relating to the performance of the goods or any part of the goods or the results that ought to be expected from using the good.

CUSTOMER CARE

- 6.1 **To claim under this warranty, you must first contact our friendly customer service team on free call 1800 079 124 or via email info@hegroup.com.au and explain the basis of your claim. Our customer service team will then provide you with directions on how to make your claim under this warranty.**

This warranty is valid with the presentation of the original proof of purchase receipt or tax invoice originating from the store of purchase for the product showing the retailer's name, date of purchase and amount paid, by you, for the good.