



PRESTO SLICER USER MANUAL



ITEM NO: 900112
MODEL NO: RG-3029

IMPORTANT SAFEGUARDS

When using the electrical appliances, basic safety precautions should always be followed, including the following:

- Read this instruction booklet carefully before operation.
- Before using the appliance, check that the mains power voltage corresponds with the voltage shown on the rating plate.
- The appliance should be connected to a correctly earthed power socket.
- Always remove the plug from the power socket when the appliance is not in use and before carrying out any maintenance operations.
- Never leave the appliance unattended when it is switched on.
- The appliance is not intended for use by young children or infirm persons without supervision.
- Young children should be supervised to ensure that they do not play with the appliance.
- This appliance is for domestic use only. Commercial use voids warranty. Use as described in this instruction booklet.
- Do not switch the appliance on if it appears to be faulty in any way.
- To protect against electric shock, do not immerse cords, plugs or the appliances in water or any other liquid.
- Do not let the power cord hang over the edge of a table or counter or let it come into contact with any hot surfaces.
- Unplug from outlet when not in use or before cleaning.
- Do not use this product for anything other than its intended use.
- To disconnect – remove the plug from the outlet. Do not pull plug out by the cord.
- For repairs or accessories contact the distributor on the contact details outlined in the guarantee.

PARTS DESCRIPTION

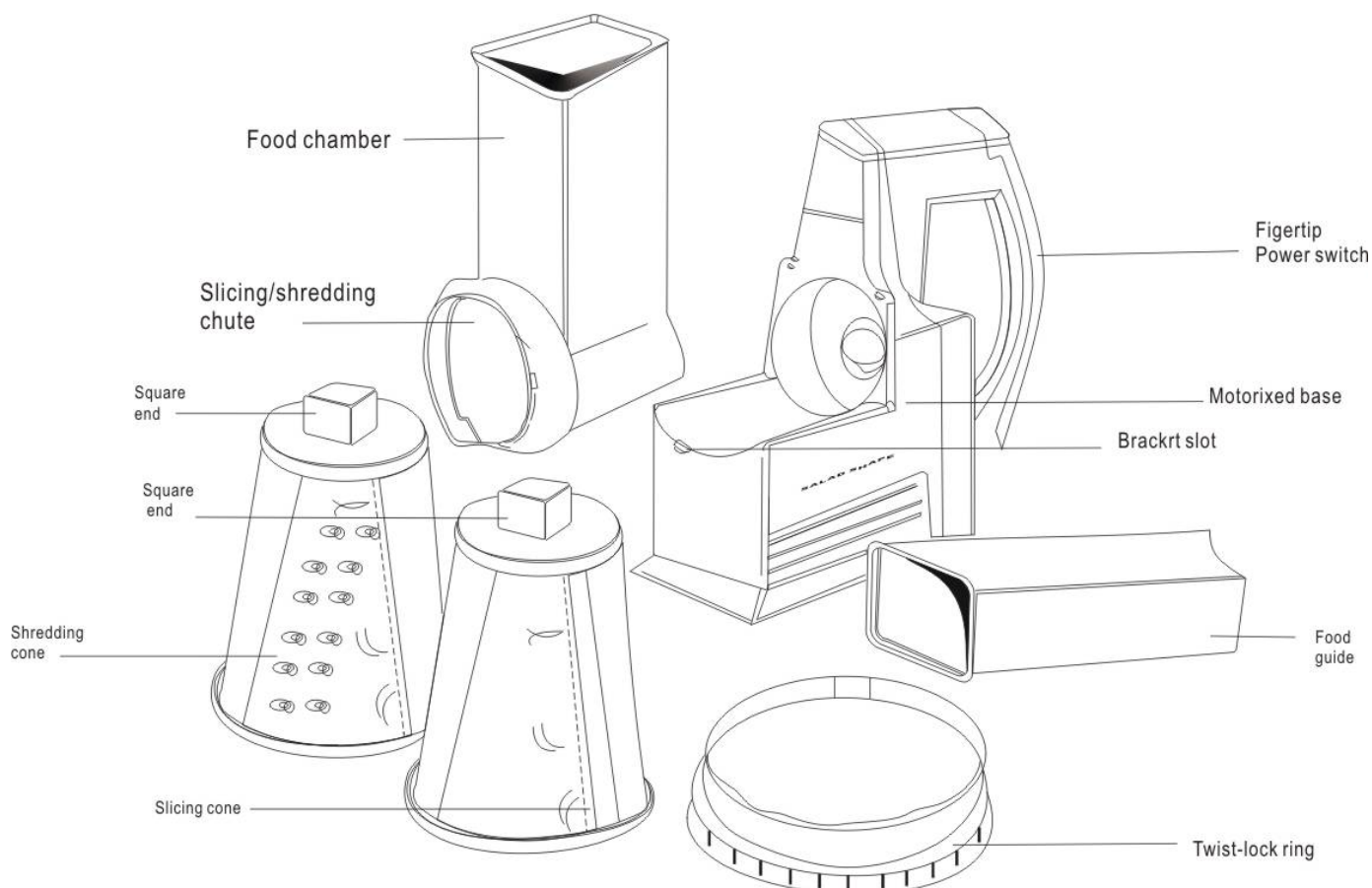

OPERATION

IMPORTANT: Always make sure the power switch is off and the cord is unplugged before you assemble or disassemble the slicer/shredder. The food chamber cannot be removed when the switch is in the 'ON' position.

1. Put together the food chamber assembly by placing either the slicing or shredding cone with the square end in first into the slicing/shredding chute (Fig. A).

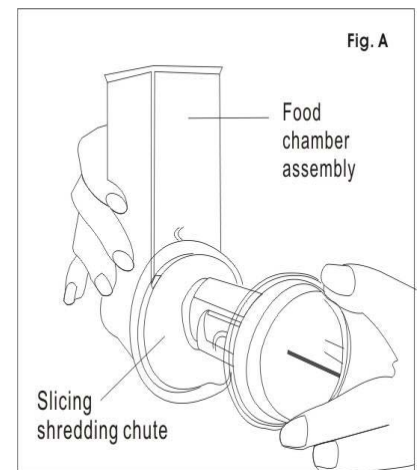

2. Put on the twist lock ring and turn it clockwise until it locks into place (Fig. 8). The metal portion of the slicing and shredding cones are sharp. Handle with care.

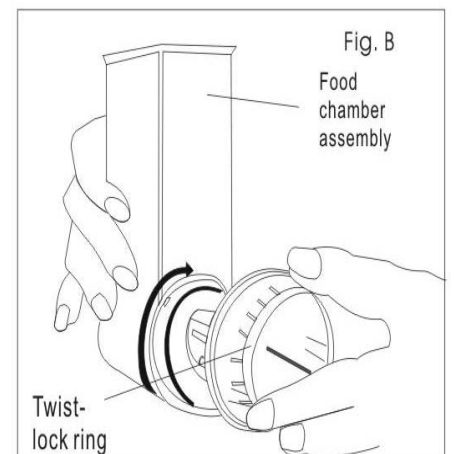

3. Attach the food chamber assembly to the motorised base by inserting the square end of the slicing or shredding cone into the socket of the motorised base (Fig C). Then rotate the food chamber assembly clockwise until it is upright and it is centred with the handle.

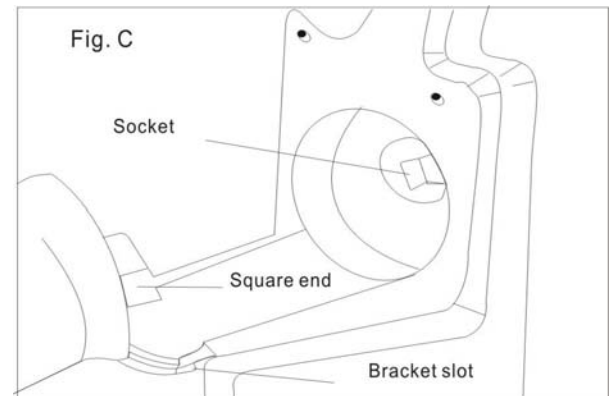

4. To be sure the food chamber assembly is attached properly; check to see that inner lock bracket is positioned in the bracket slot (Fig. D). Proper assembly is important.

5. Plug the unit in, load the food chamber and you can begin slicing or shredding.

6. Use the fingertip power switch to turn the unit on and off.

7. For best slicing and shredding results, it is important that the food be prepared and placed in the food chamber as follows:

- Cut food so that it will easily and loosely fit into the food chamber.
- Stack food into the food chamber upright for short slices or horizontality for longer thinner slices
- Push food through the food chamber using an even pressure on the food guide.

Cut foods to fit loosely in the food chamber

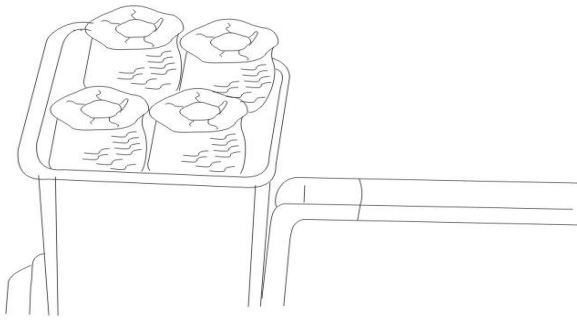

Stack food upright for small slices

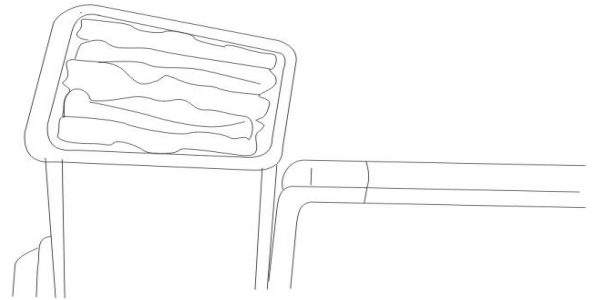

Stack food horizontally for longer slices

CAUTION: To avoid personal injury, never load the food through the food chamber with your hands, always use the food guide and always keep your hands away from the slicing/shredding chute when the slicer/shredder is running.

- The sliced or shredded food will be discharged from the open end of the slicing/shredding chute (Fig. E), allowing you to easily shoot toppings right onto your salad, pizza or dessert, so there are no extra bowls to clean.

Fig. E

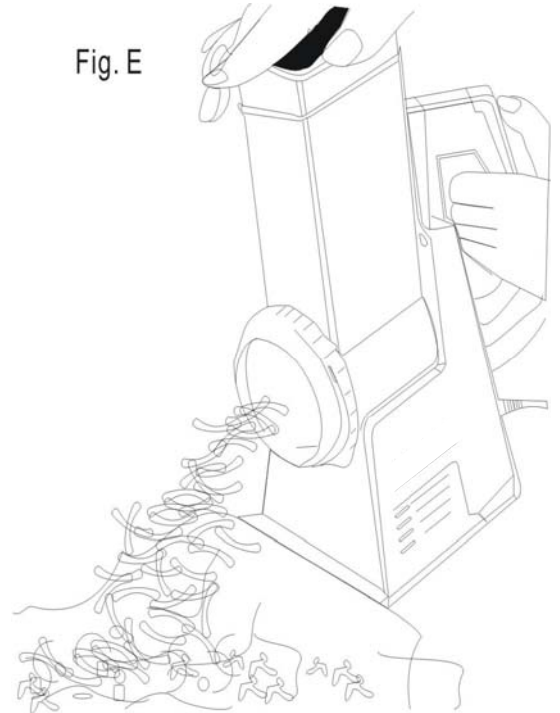

TO SLICE

Fruits (such as peeled apples, bananas, nectarines, peaches, pears); vegetables (such as cabbage, carrots, celery, chilli peppers, cucumbers, green peppers, lettuce, mushroom, onions, potatoes, radishes, turnips, zucchini); nuts, olives, pickles.



NOTE: This attachment is not designed to slice cheese, meats, tomatoes or chocolates.

Cabbage, lettuce (Cabbage and lettuce will come out shredded).

Use the slicing cone. Foods should be cut to into the food chamber. Turn the unit on and use the food guide to feed food through the unit into your bowl.

NOTE: Use light pressure on the food guide for thinner slices and firm pressure for thicker slices.

For longer slices, pack food horizontally into the food chamber. For shorter slices, pack food vertically into the food chamber. For best results, leafy vegetables, such as cabbage and lettuce should be cut into chunks the size of the food chamber.

TO SHRED

Fruits (such as peeled Apples, coconut, maraschino cherry, Nectarines, pears, peaches); vegetables (such as carrots, chilli peppers, potatoes, zucchini); semi-soft cheeses (such as cheddar, Mozzarella and Swiss): nuts, chocolate



Use the shredding cone. Food should be cut into the food chamber. Semi-soft cheeses such as cheddar, Mozzarella and Swiss should be well chilled before shredding. Turn the unit on and use the food guide to feed food through the unit into your bowl or onto your pizza. NOTE: For shorter shreds, pack food vertically into the food chamber and for longer shreds pack food horizontally into food chamber. NOTE: The unit is not designed to shred onions.

TO CRUMB

Wafer, dry or fresh bread, biscuits, crackers, potato chips



Use the shredding cone. Place pieces of food into the food chamber. Turn the unit on and use the food guide to feed food through the unit.

TO GRATE

Carrots, cucumber, zucchini, chocolate, hard boiled eggs, hard cheeses such as Parmesan or Romano, nuts, semi-soft cheeses such as cheddar, Mozzarella or Swiss.



Use the shredding cone. Hard cheeses should be of room temperature and semi-soft cheeses should be at refrigerated temperatures. Place the food in the food chamber. Turn the unit on and use the food guide to feed food through the unit.