

AVITA

ICE CREAM MAKER USER MANUAL



Item No: 900360

IMPORTANT SAFEGUARDS

When using the electrical appliances, basic safety precautions should always be followed, including the following:

- Read this instruction booklet carefully before operation.
- Before using the appliance, check that the mains power voltage corresponds with the voltage shown on the rating plate.
- The appliance should be connected to a correctly earthed power socket.
- Always remove the plug from the power socket when the appliance is not in use and before carrying out any maintenance operations.
- Never leave the appliance unattended when it is switched on.
- This appliance is not intended for use by persons (including children) with reduced physical, sensory or mental capabilities, or lack of experience and knowledge, unless they have been given supervision or instruction concerning use of the appliance by a person responsible for their safety.
- Young children should be supervised to ensure that they do not play with the appliance.
- This appliance is for domestic use only. Commercial use voids warranty. Use as described in this instruction booklet.
- Do not switch the appliance on if it appears to be faulty in any way.
- To protect against electric shock, do not immerse cords, plugs or the appliances in water or any other liquid.
- Do not let the power cord hang over the edge of a table or counter or let it come into contact with any hot surfaces.
- Do not use this product for anything other than its intended use.
- To disconnect – remove the plug from the outlet. Do not pull plug out by the cord.
- For repairs or accessories contact the distributor on the contact details outlined in the guarantee.
- Do not use the appliance outdoors.
- Please keep the appliance sitting upwards when no in use.
- Keep hands and utensils out of the bowl when in use.
- Do not put sharp objects or utensils inside the bowl. This may cause scratching and damage to the inner surface or the bowl. A rubber spatula or wooden spoon may be used when the appliance is in the “off” position.
- Do not use the appliance for more than 30mins at a time. It should be turned off and rested for 30 mins after each use.

Directions For Use

Please ensure you clean the unit before each use. The bowl, bowl cover and mixing arm can be washed in warm soapy water, rinsed and dried. Do not use harsh scrubbing materials, use only soft non abraisive objects. Do not submerge the Motor unit in water. It can be wiped with a damp sponge and dried off.

1. Motor Housing

2. On/Off switch

3. Spindle

4. Freezing bowl Lid

5. Mixing Arm

6. Freezing Bowl

7. Cord and Plug

8. Locking clips

9. Pouring hole

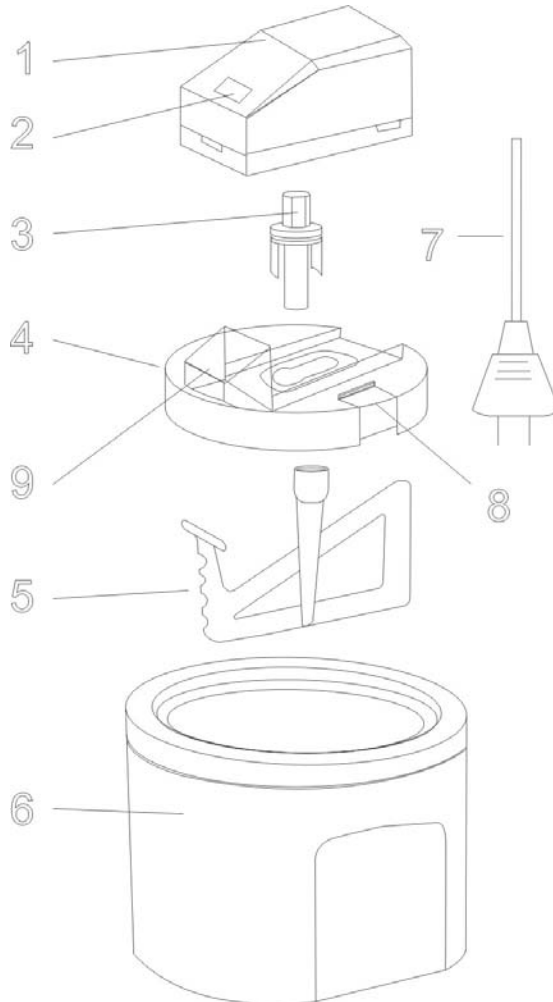

Making Ice Cream

Place the mixing bowl in the freezer. This will need to be left in the freezer for at least 8 hours for best results. It is recommended that the bowl be placed in an upright position towards the back of the freezer where it is coldest. The frozen bowl should be used immediately after removing from the freezer. Delaying use once it has been removed will not be as effective. Continually storing the bowl in the freezer will give you the flexibility to make your favourite frozen desert at any time.

Once thoroughly frozen, remove the mixing bowl from the freezer. Slide the motor unit half way onto the mixing bowl cover and insert the mixing arm into the motor unit so it fits into the large round opening through the underside of the mixing bowl cover. Once inserted slide the motor unit completely onto the mixing bowl cover.

Ensure the locking clips on the side of the bowl cover are pushed inwards and place the bowl cover onto the mixing bowl. Ensure that the locking clips are lined up with the clips on the mixing bowl. Push the locking clips on the top of the bowl cover outwards to lock the cover in place.

Plug the unit in and switch to the “on” position. The mixing arm should now be slowly rotating inside the bowl.

Slowly pour your prepared ice cream ingredients (see recipes in this booklet) into the frozen bowl through the opening at the front of the unit. (it is recommended to use pre chilled ingredients for best results) **Do not add warm or hot ingredients to the mixing bowl.**

Leave the unit on for approx 15-20 minutes. The consistency of the ice cream will vary depending on the ingredients used. If after 20 minutes the ice cream is still too soft, remove the bowl cover, mixing arm and motor unit and place the mixing bowl back in the freezer for a further 30 minutes. Alternative you can remove the ice cream from the bowl and place into a freezer safe container and place back in the freezer.

Do not use sharp or metallic utensils to remove the ice cream from the bowl. Use a rubber spatula or wooden spoon. Metallic utensils may damage the lining of the bowl.

Raspberry Sorbet

3 cups fresh raspberries ½ cup of water

2/3 cup of sugar 2 egg whites

½ cup of orange juice

In a saucepan over medium heat, add the raspberries, water and sugar. Stir until sugar is dissolved. Puree then chill thoroughly. Beat egg white until soft. Add orange juice to raspberries then whisk in the whisked egg whites.

Kiwi Fruit Sorbet

6-8 Peeled kiwi fruit 2 ½ cups water

2/3 cup of sugar 2 egg whites

2 tablespoons lemon juice

In a saucepan over medium heat, add the lemon juice water and sugar. Stir until sugar is dissolved. Puree the kiwi fruit with the sugar syrup then chill thoroughly. Beat egg white until soft. Whisk in the egg whites to the mixture.